



**FUSION
FOR
ENERGY**

BRINGING
THE **POWER**
OF THE **SUN**
TO **EARTH**

**F4E-OMF-1609
Information Day
DAT Cask Platform for
Divertor Assembly (CPD-MA)**

Darren Locke

Project Manager

Cask and Plug Remote Handling System

4th November 2024

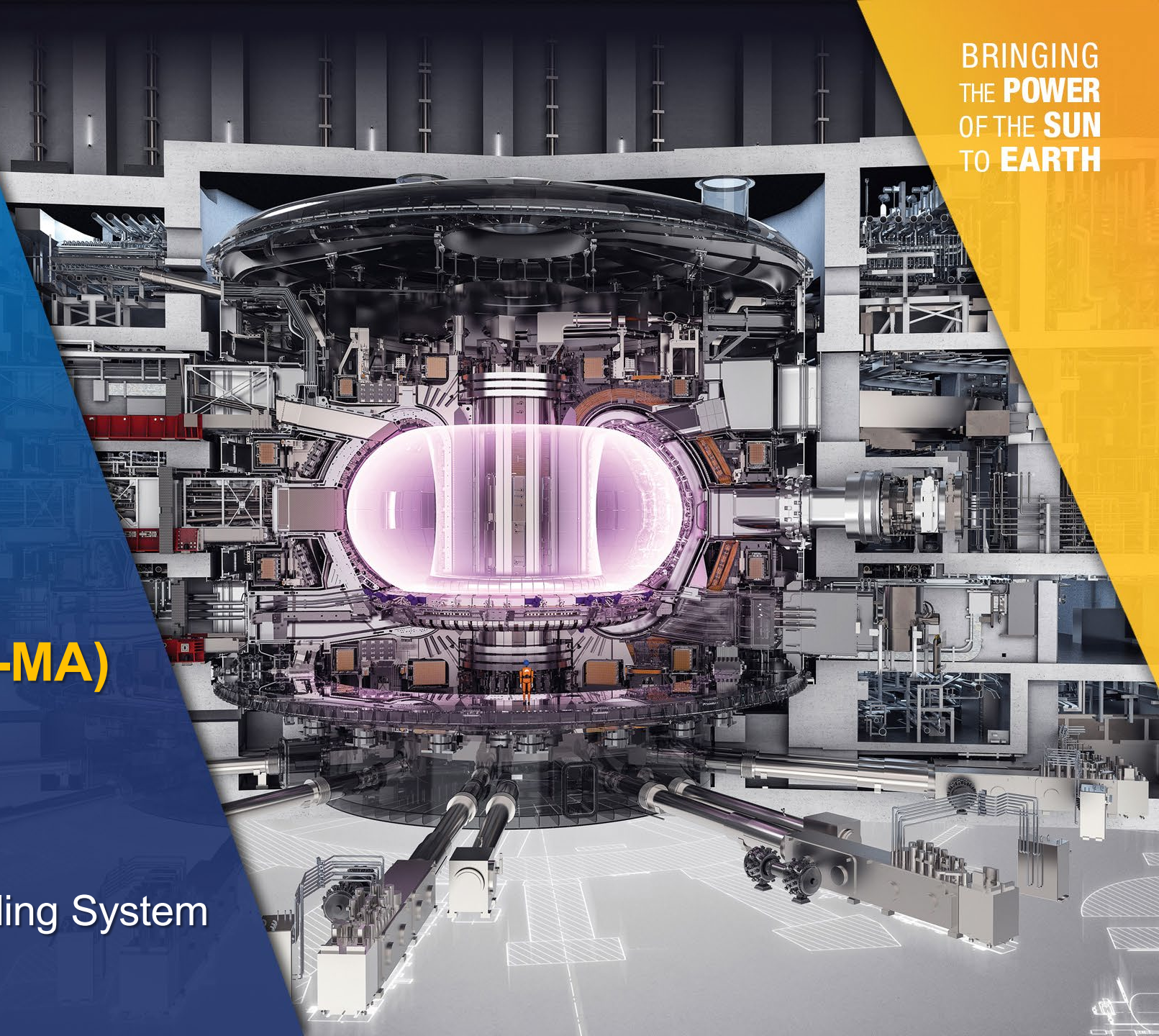

Support DAT CMM & payloads

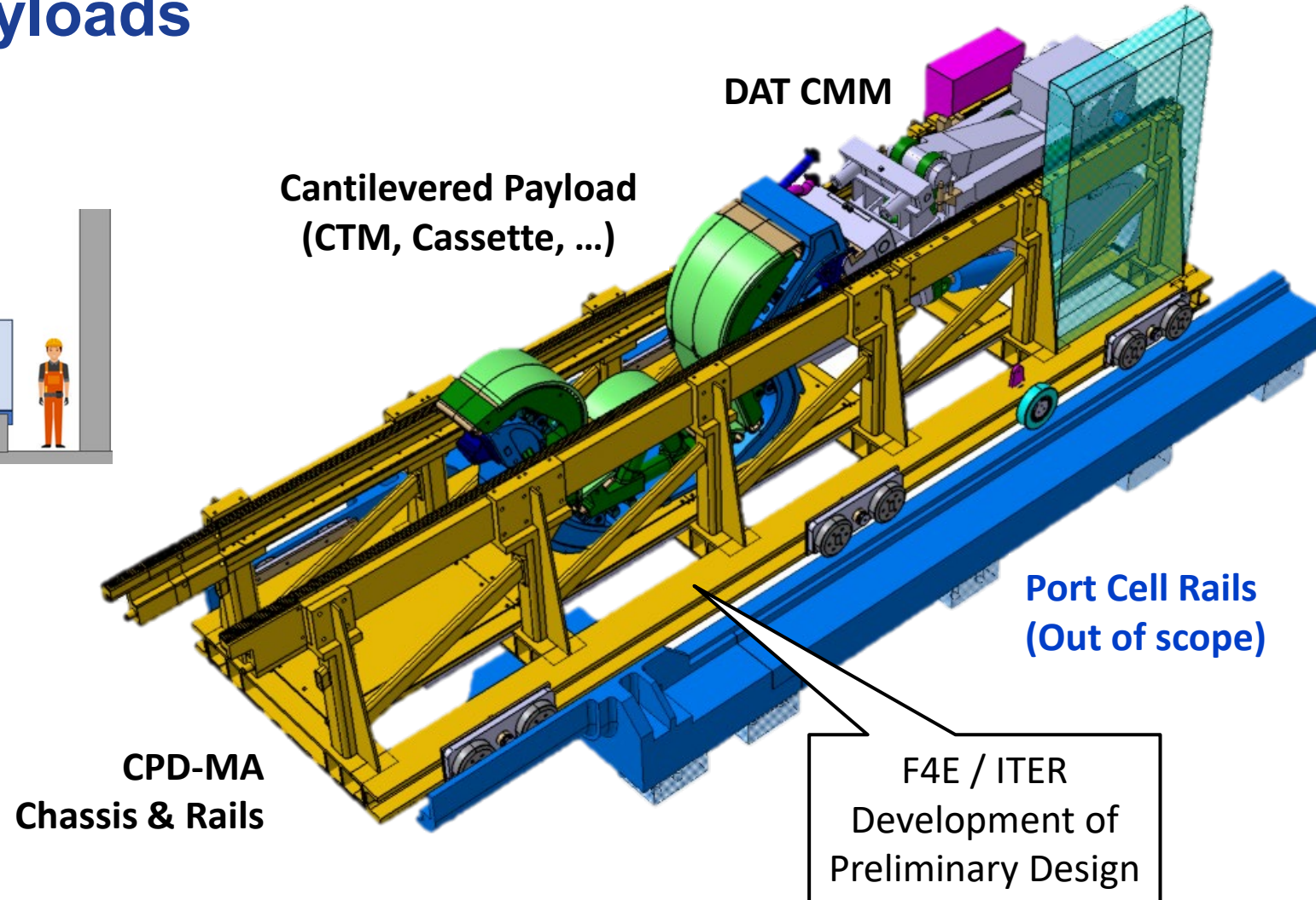
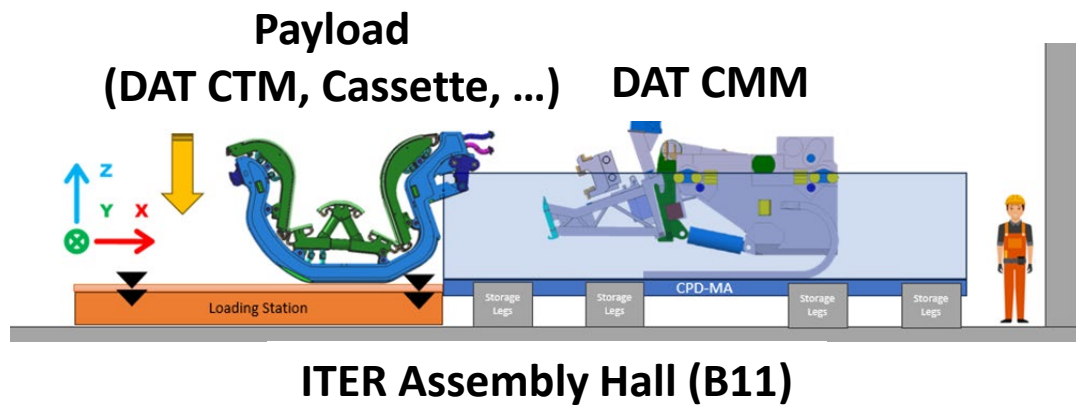

Support DAT CMM & payload During Transportation

CPD moves
through the
galleries &
Lift

ITER Assembly
Hall (B11)

Tokamak
Building (B21)

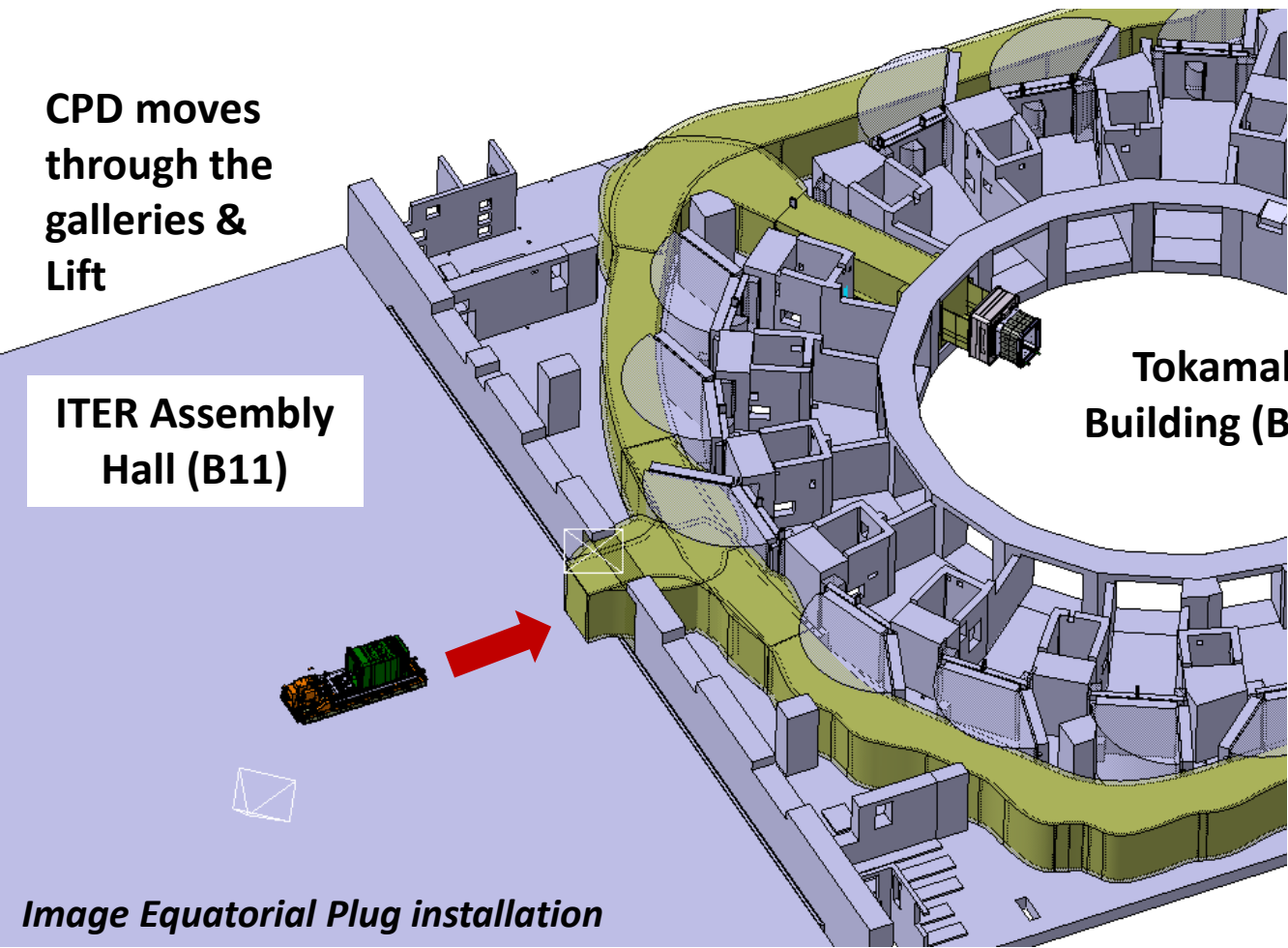
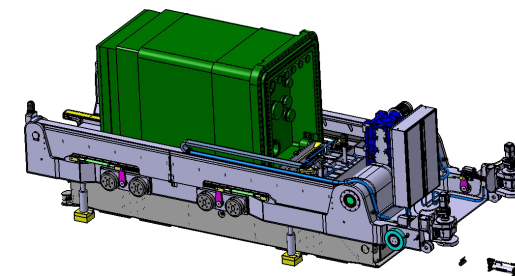
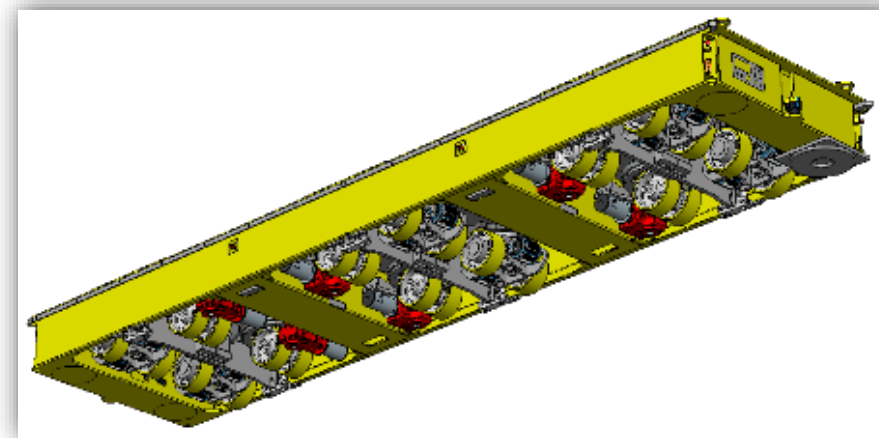

Image Equatorial Plug installation



Existing Port Plug Transport



Transportation System (Out of scope)

Support DAT CMM During Transportation

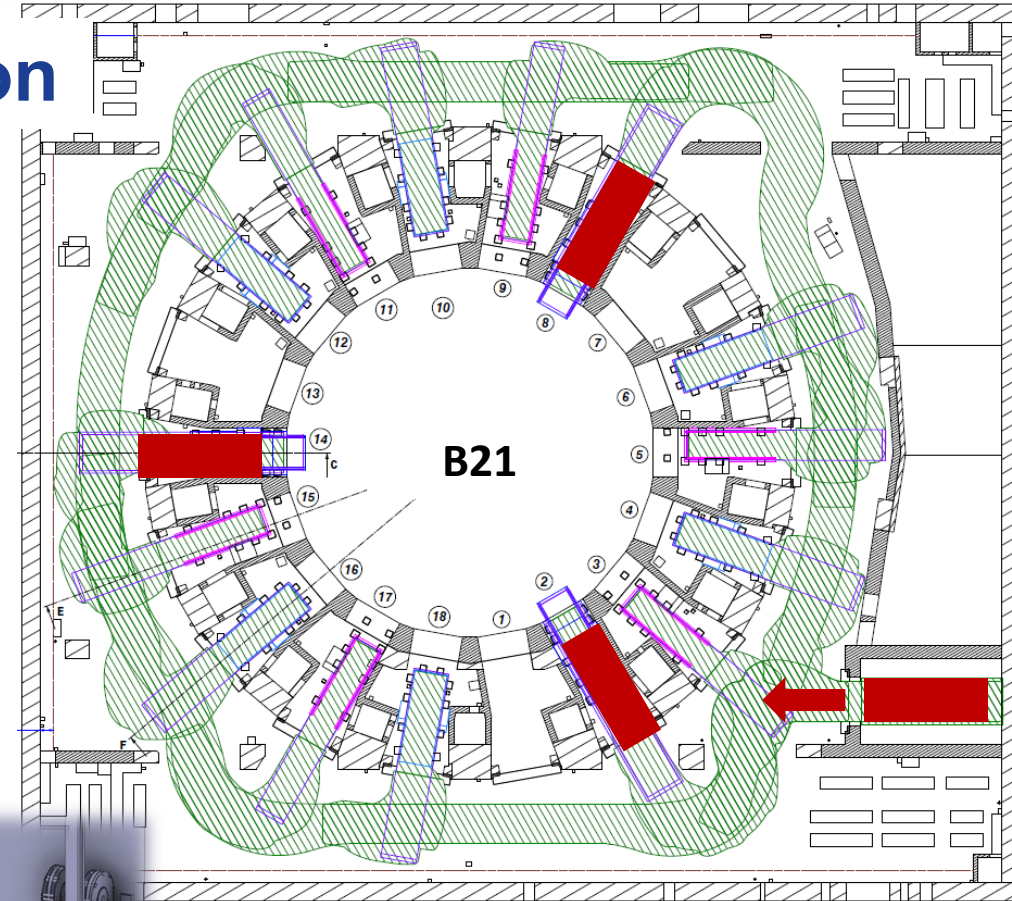

Lower Level B1

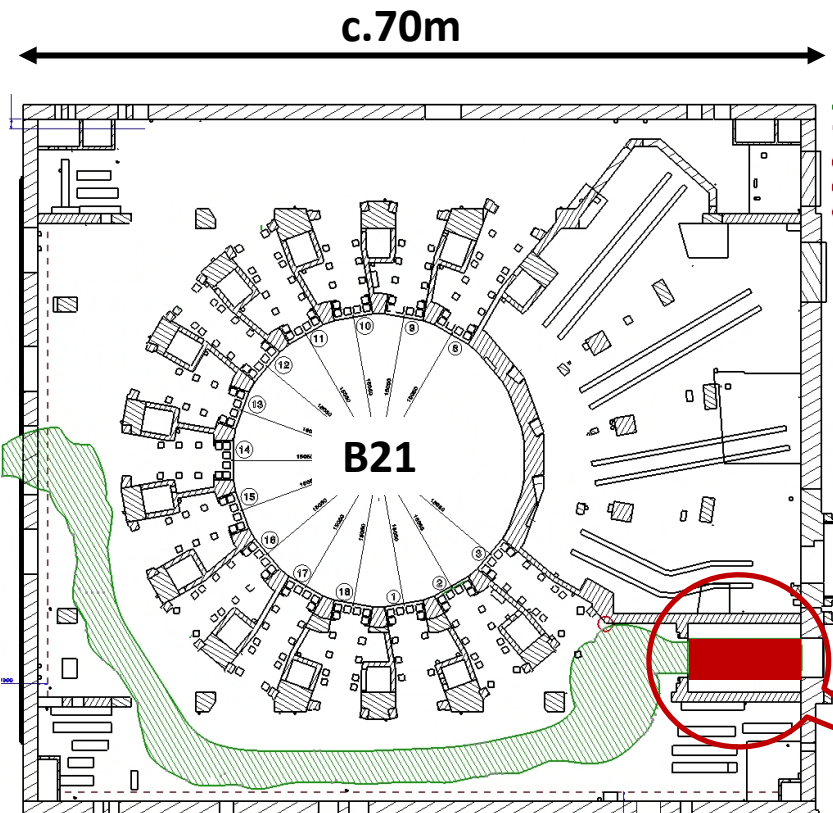

Equatorial Level L1

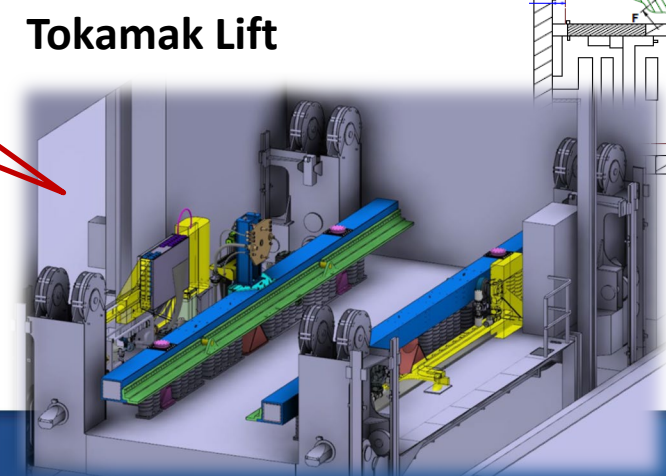

Tokamak Lift

Support DAT CMM During Port Cell Entry

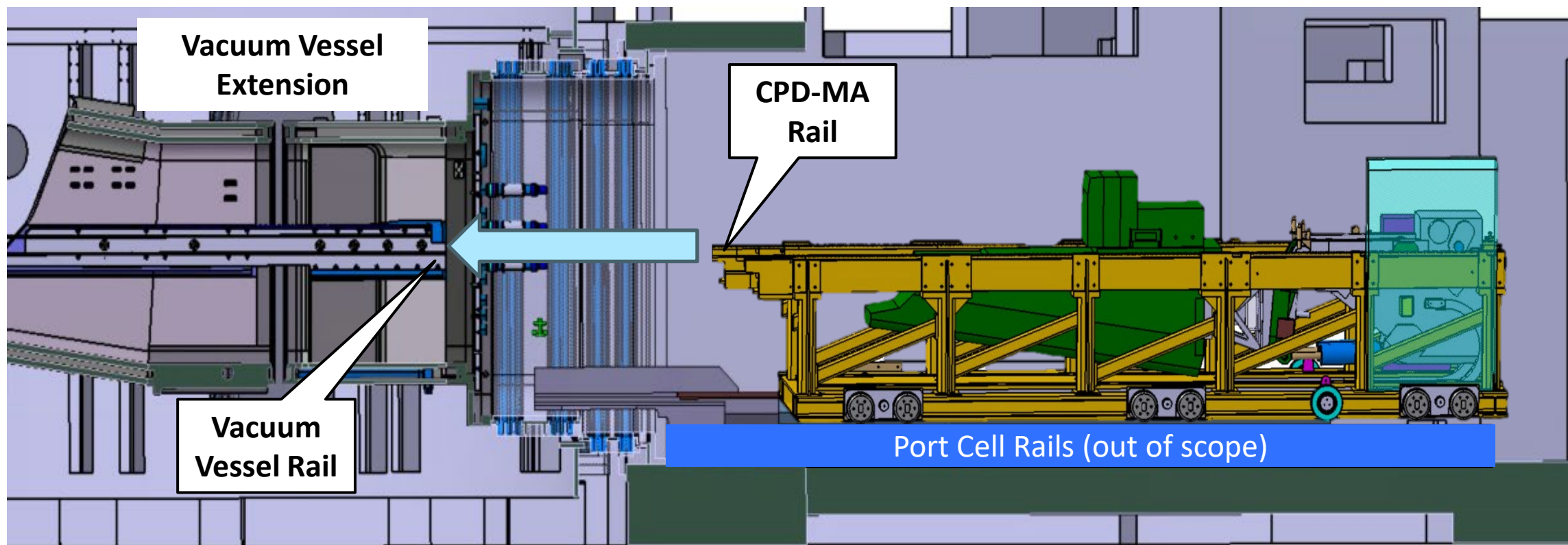

Support DAT CMM During Port Cell Entry

Vacuum Vessel
Extension

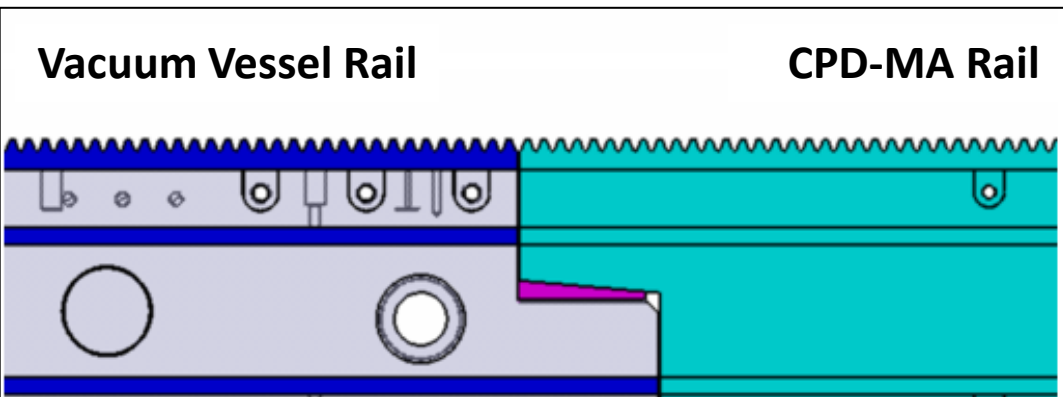
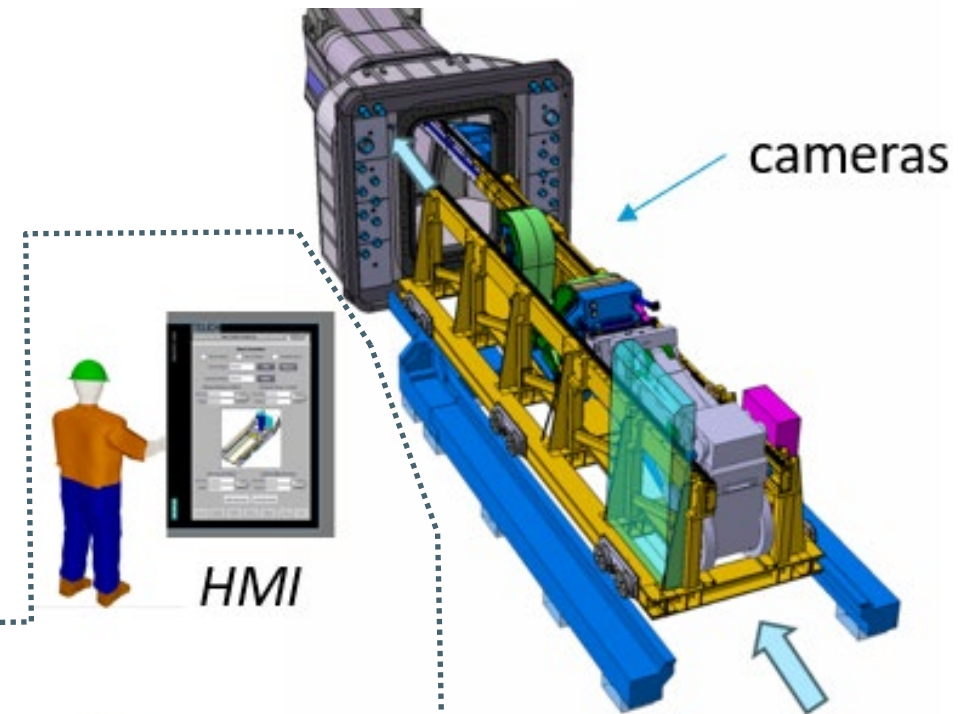
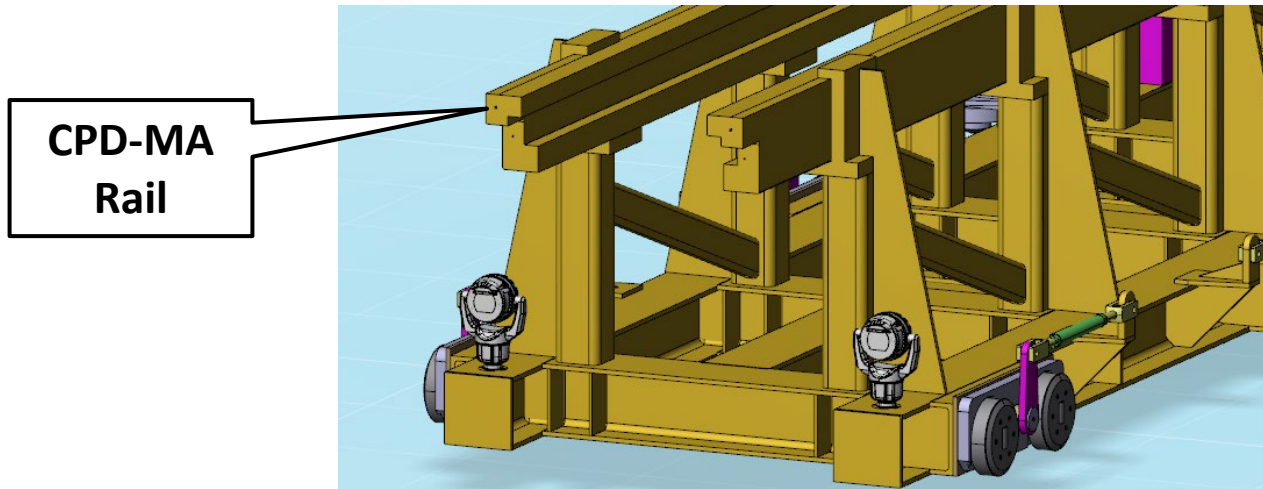

Support DAT CMM & other payloads During Divertor Installation

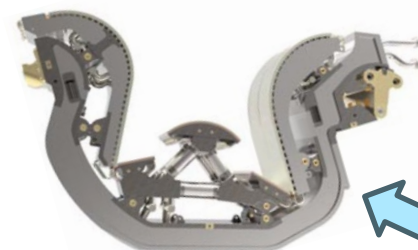
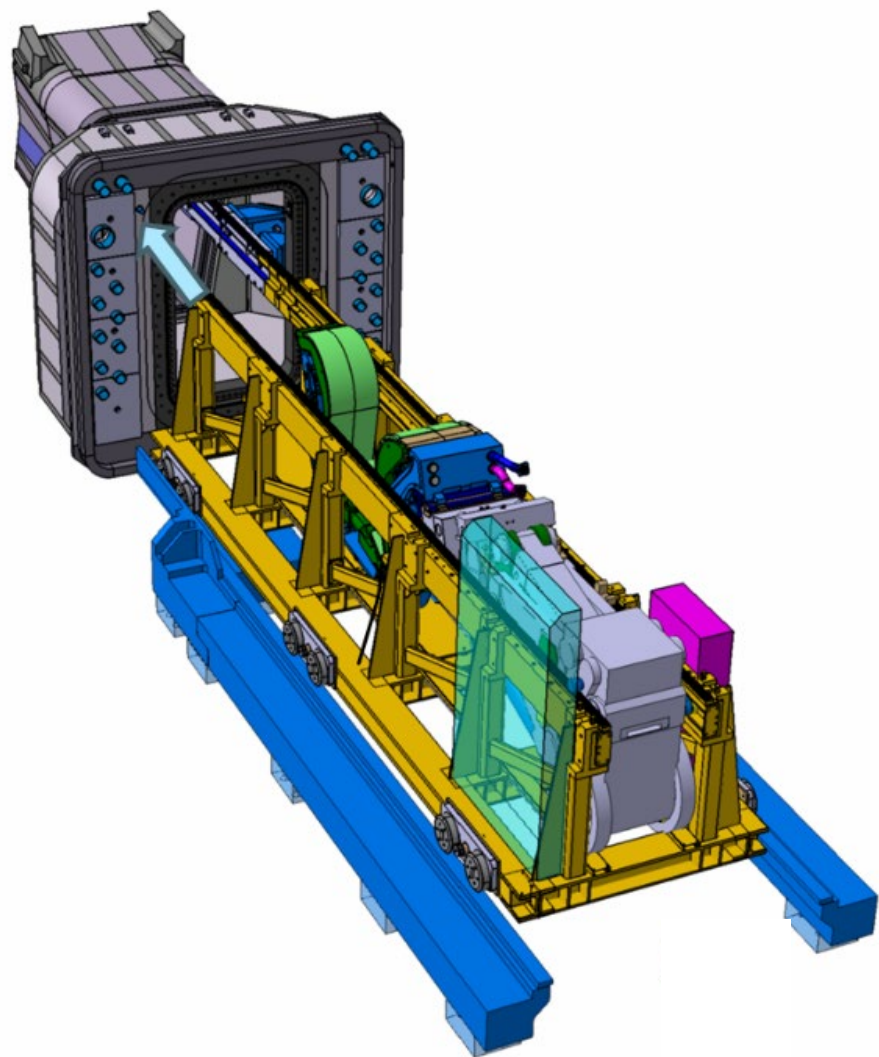

Divertor Cassette

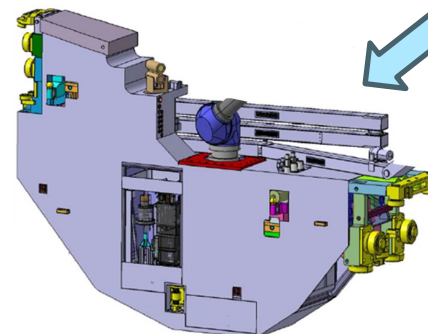

DAT CTM

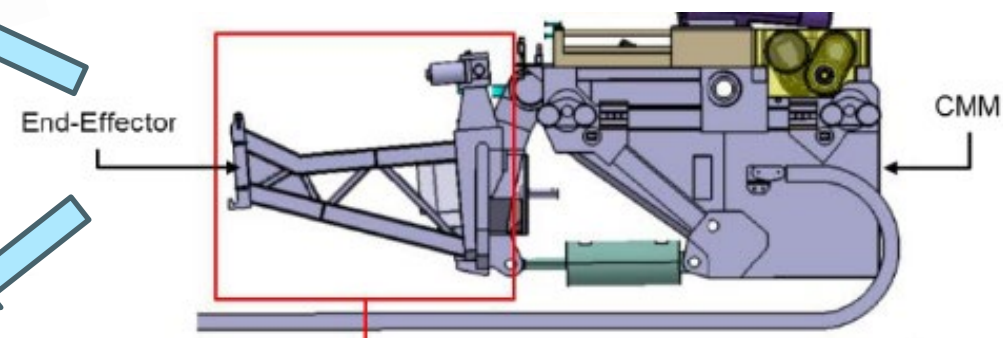

DAT CMM

System Characteristics

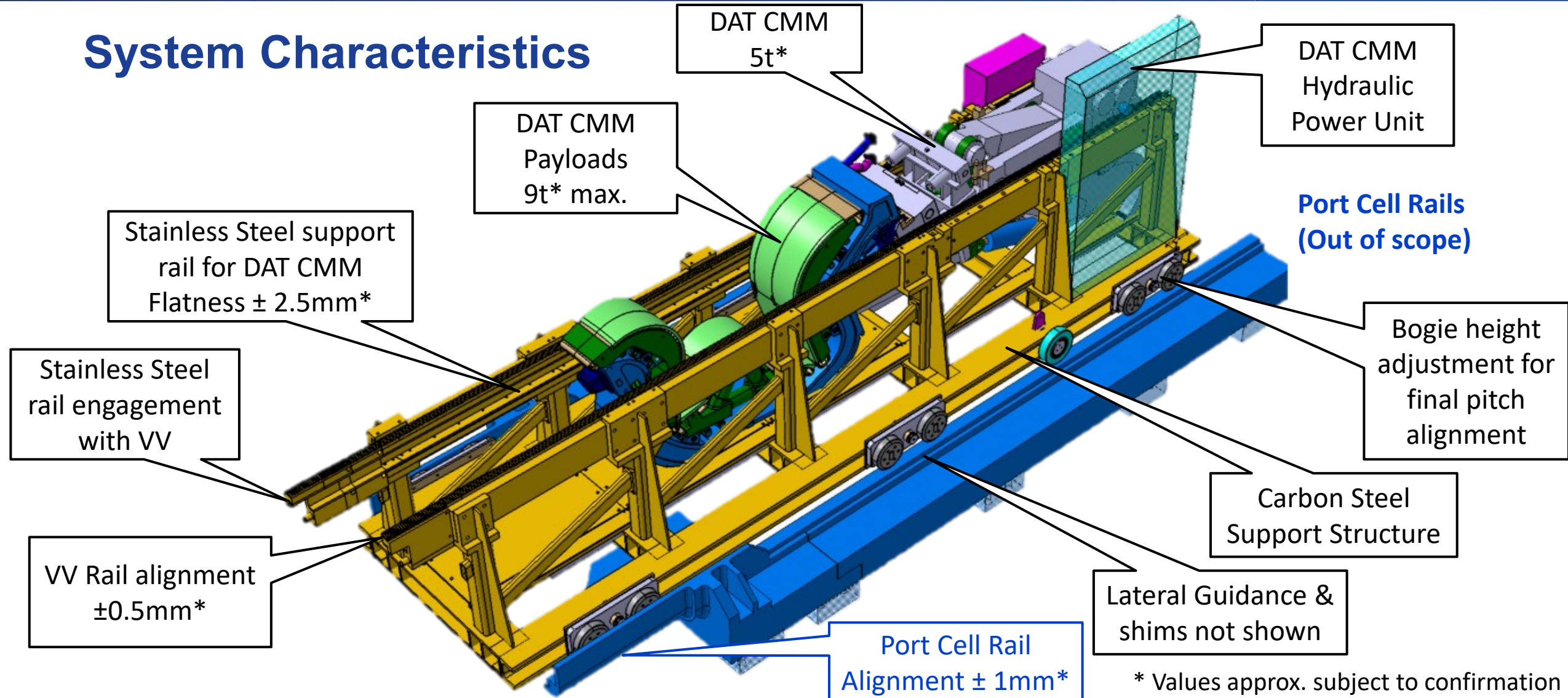

System Characteristics

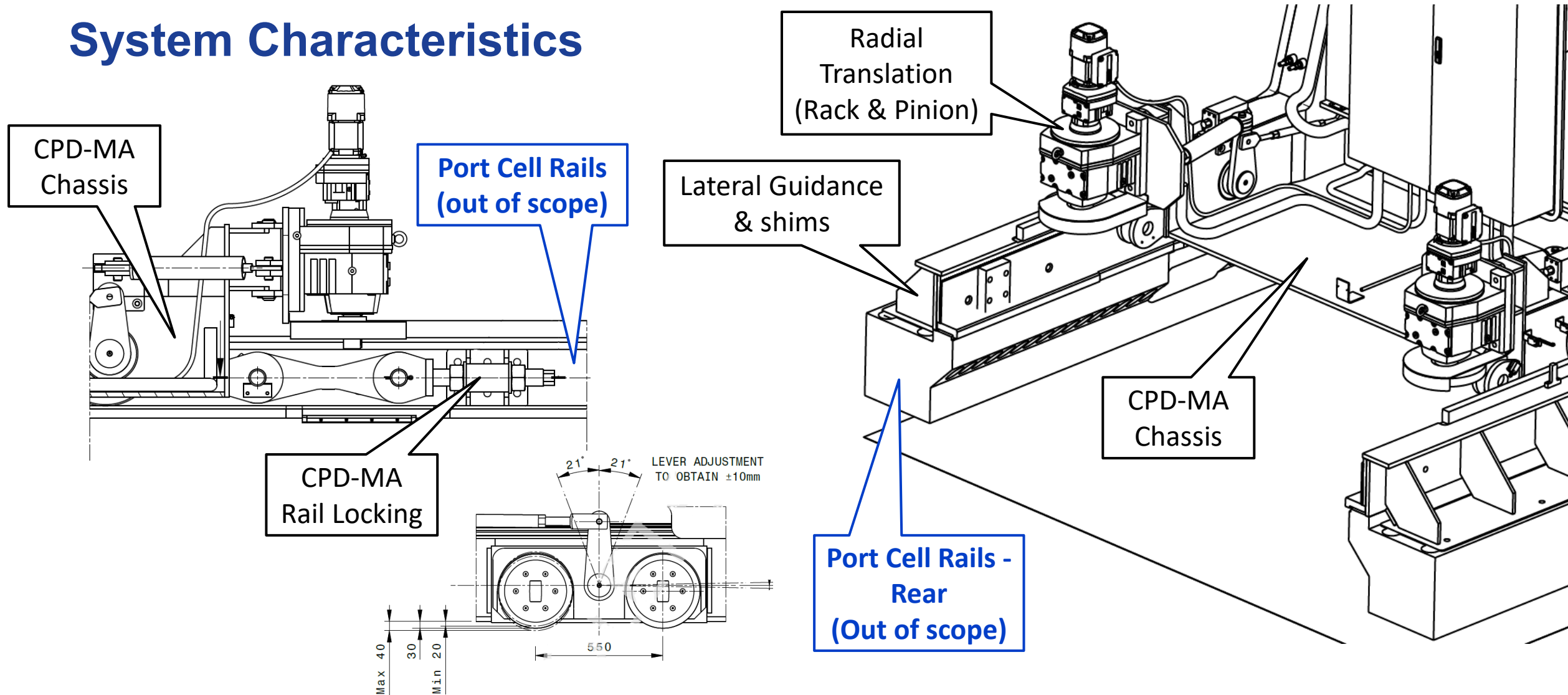

System Interfaces

- Mobile system involving many interfaces
- Internal (DAT) & External Interfaces

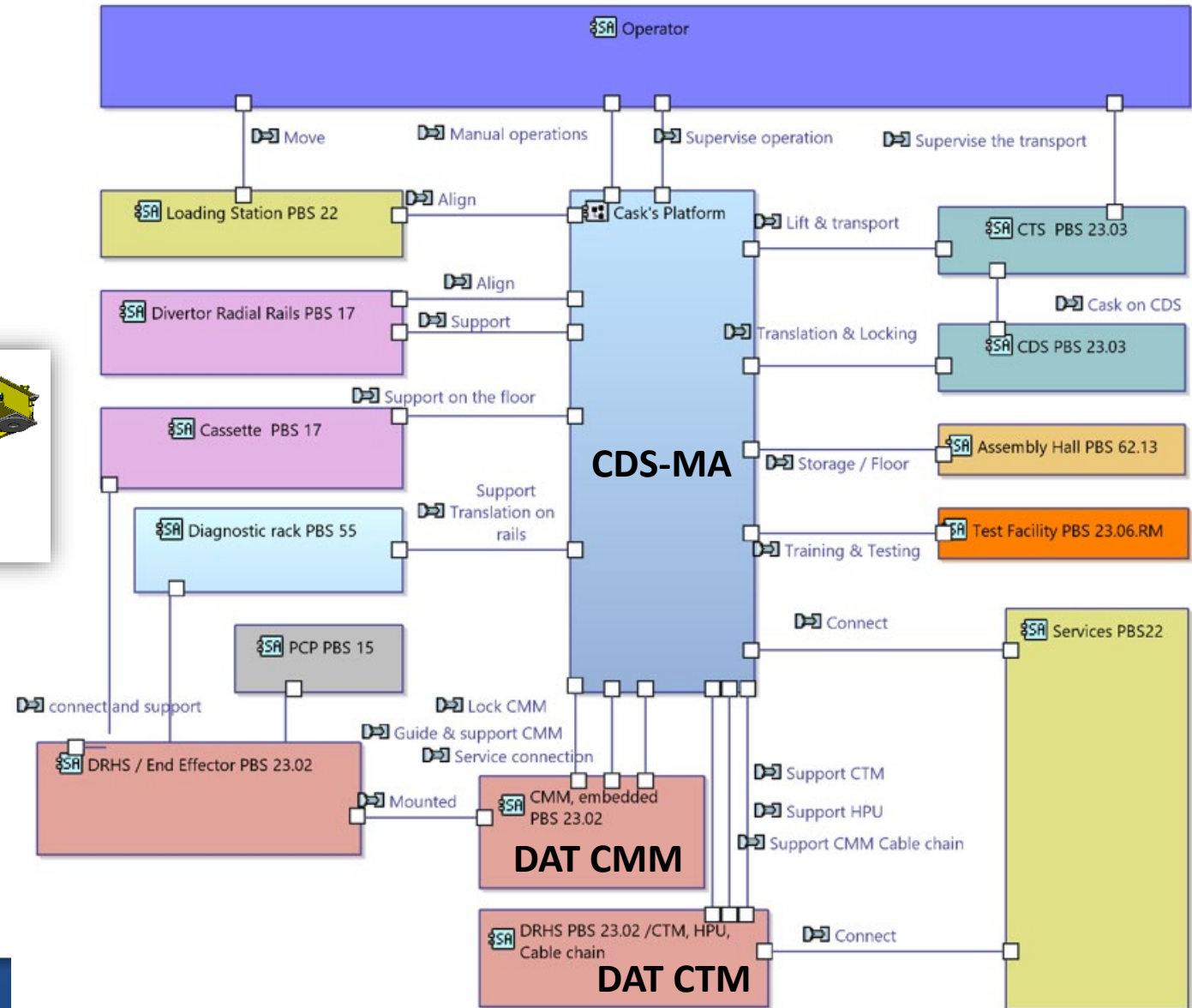
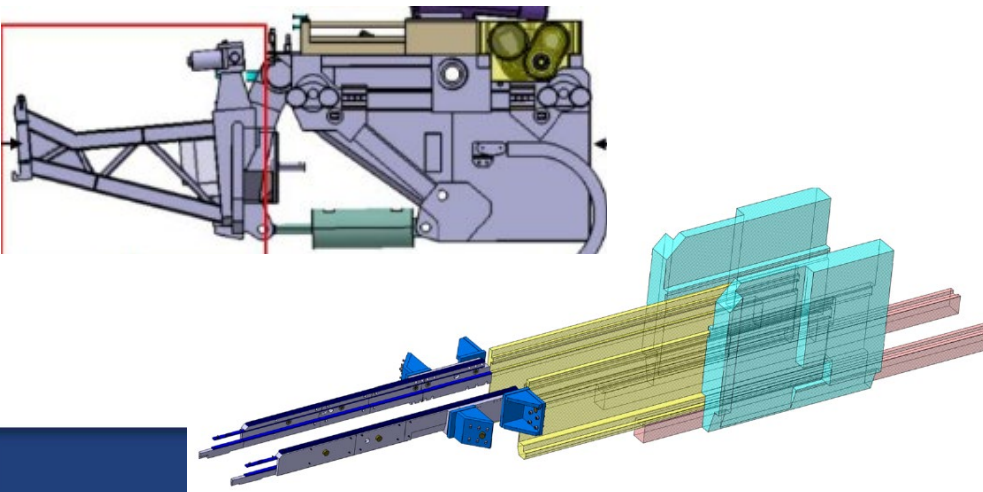
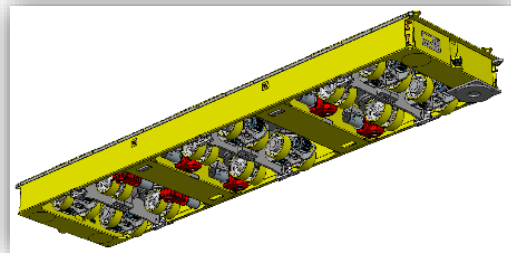



**FUSION
FOR
ENERGY**

Thank you for your attention

.....

Follow us on:



www.f4e.europa.eu



www.twitter.com/fusionforenergy



www.youtube.com/fusionforenergy



www.linkedin.com/company/fusion-for-energy



www.flickr.com/photos/fusionforenergy



Bringing
the power
of the sun
to earth