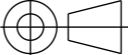

	1	2	3	4	5	6	7	8					
A													
B													
C													
D													
E					--A	UPDATED ACCORDING TO WP --B		16 May 23					
					---	FIRST EDITION		01 Apr 22					
F					REV No.	DETAILS OF MODIFICATION	SHEET No.	GRID REF	DATE	DCR No.			
					DRW CAD ID	4JYJYS	APPROVED BY	ITER Organization		LEGAL OWNER			
					LINKED EV5 PT ID	4U256L	ROTTIC	INTERNAL USE		 <small>china EU india japan korea russia USA</small>			
					LINKED 3D ID	4U25W8	TECHNICAL REF	When received pursuant to a contract or agreement, the confidentiality clause therein shall be applicable.					
					PBS TITLE	Neutral Beam H&CD System HNB01 injector Passive magnetic shield	ELOUAZA	When received during tender phase treat as confidential.					
					DATE OF ISSUE	16 May 23	PT MATURITY	--	PT VERSION	--B			
					DR STATUS	W	SCALE	1:1	PT STATUS	W			
					THIRD ANGLE PROJECTION			FORMAT	PBS NUMBER	DRAWING NUMBER	SHEET	N°OF SHEETS	REVISION
								A3	53 01 PM	062635	01	02	--A

Spacereservation for the banner

Spacereservation for the banner

FRONT VIEW

SECTION VIEW B-B

REAR VIEW

DETAIL G
Scale: 5:1

SECTION VIEW C-C
Scale: 1:1
APPLICABLE 20 TIMES

ISOMETRIC VIEW

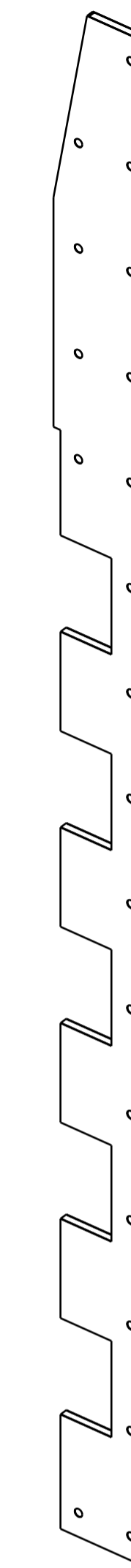
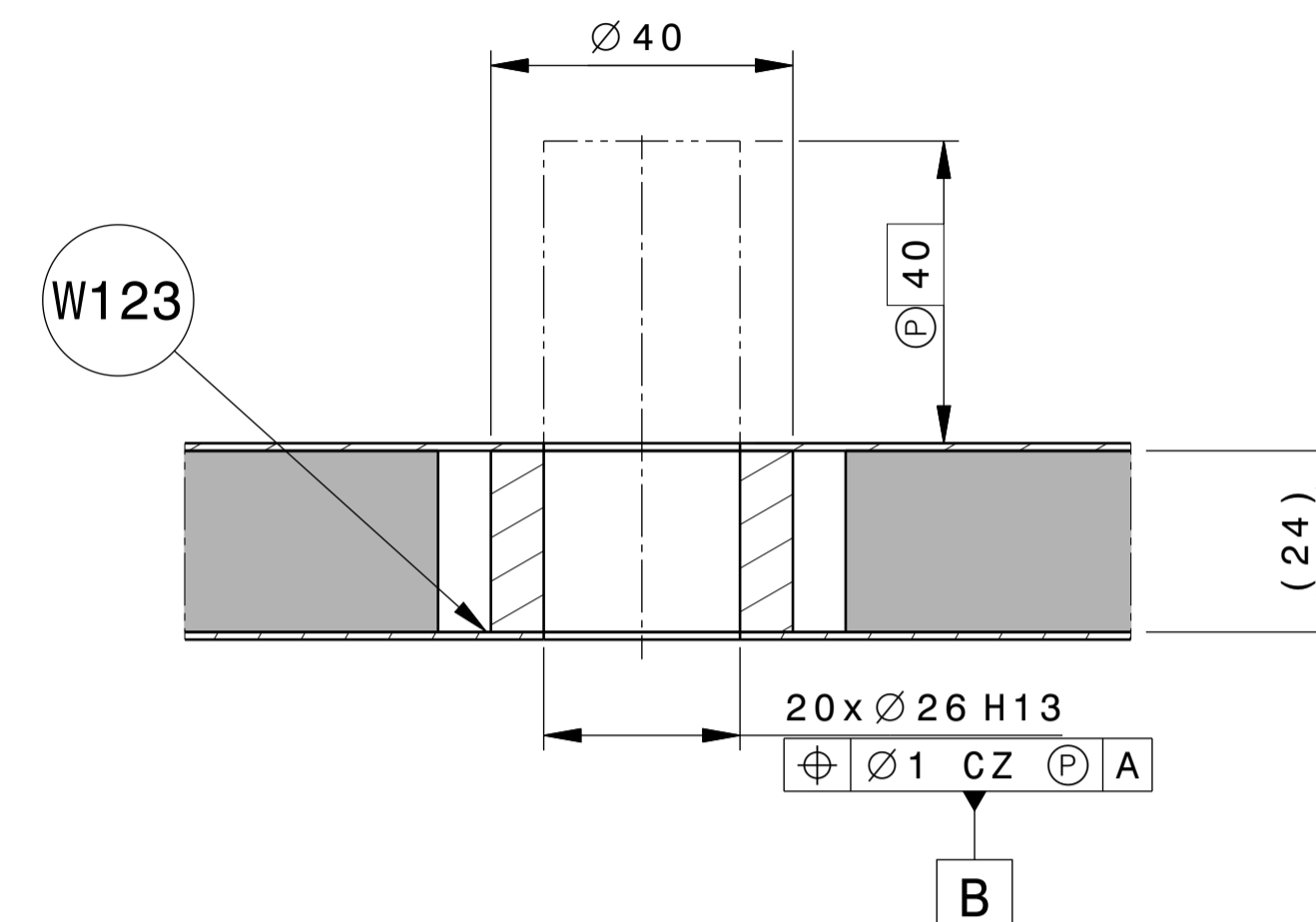
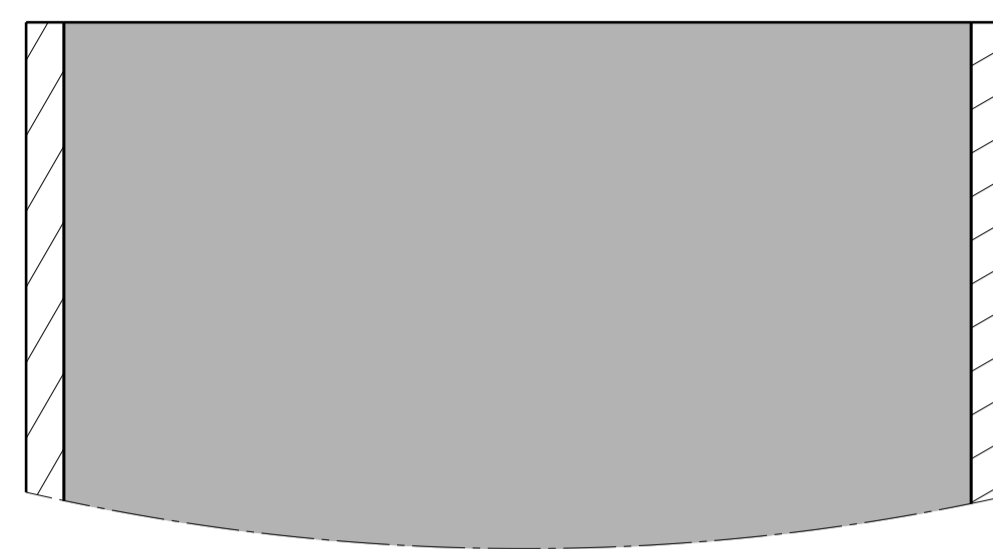
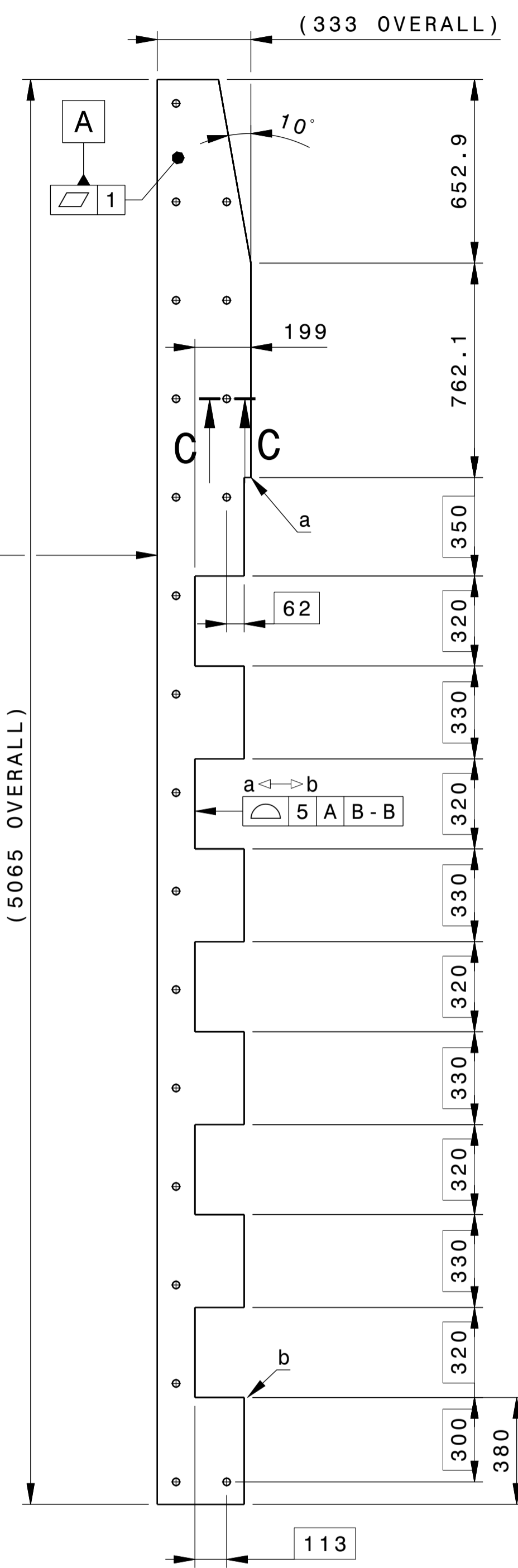
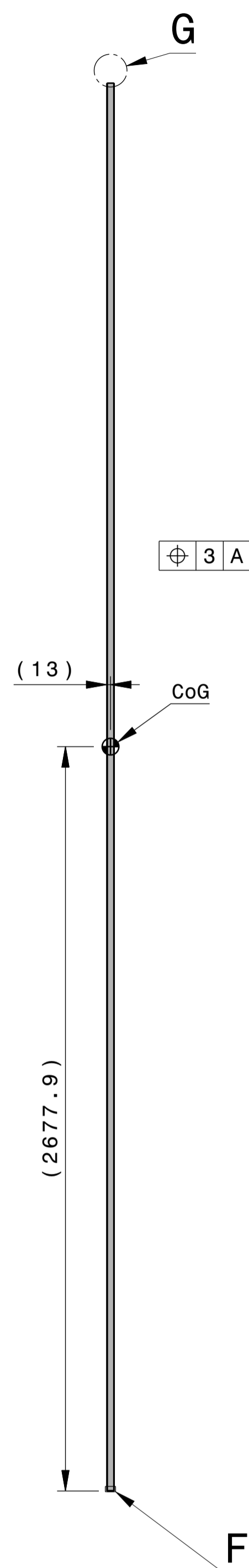
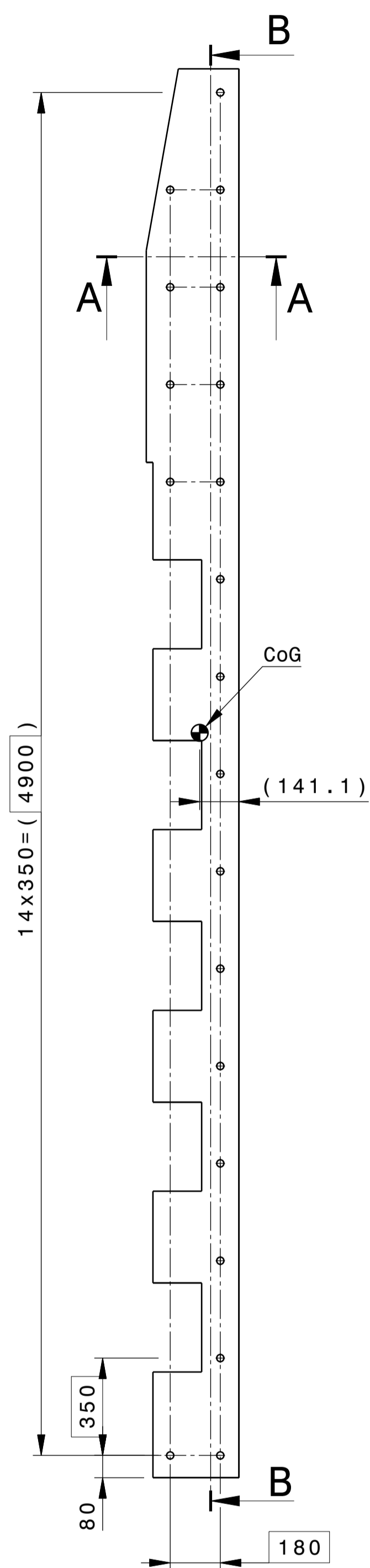

SECTION VIEW A-A
Scale: 1:2

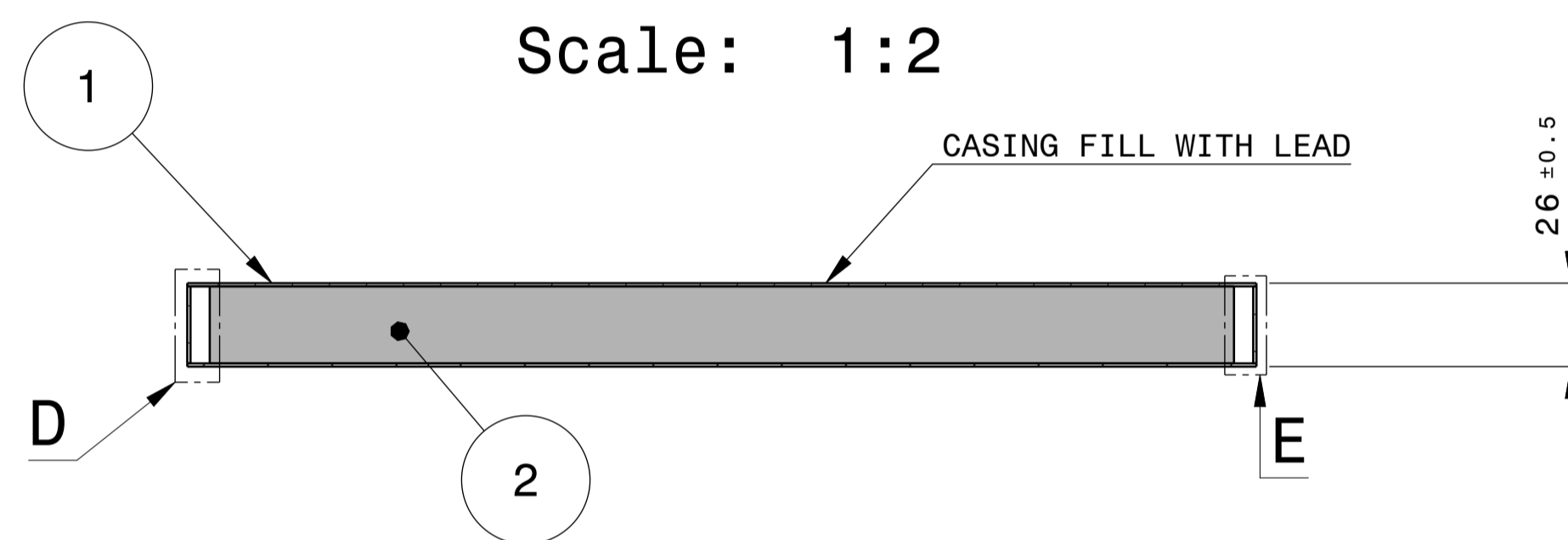

DETAIL D
Scale: 3:1

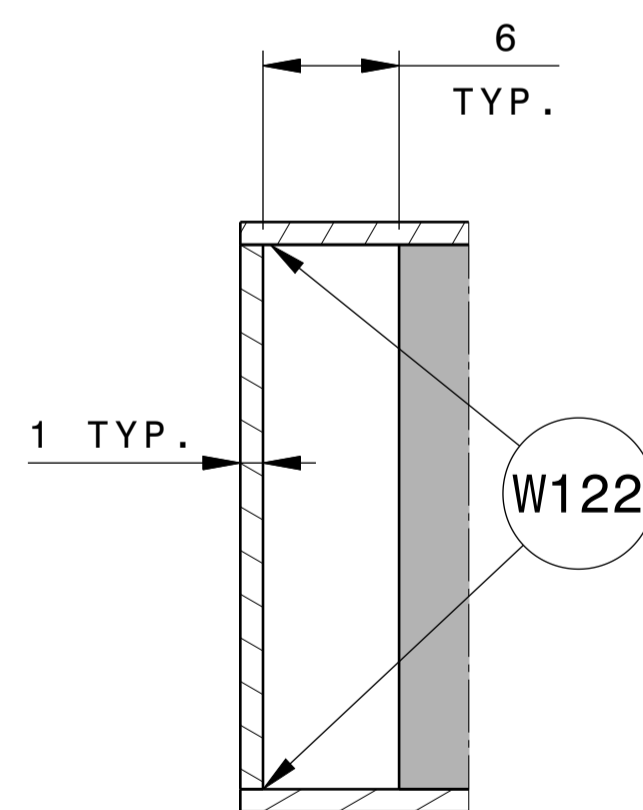

DETAIL E
Scale: 3:1

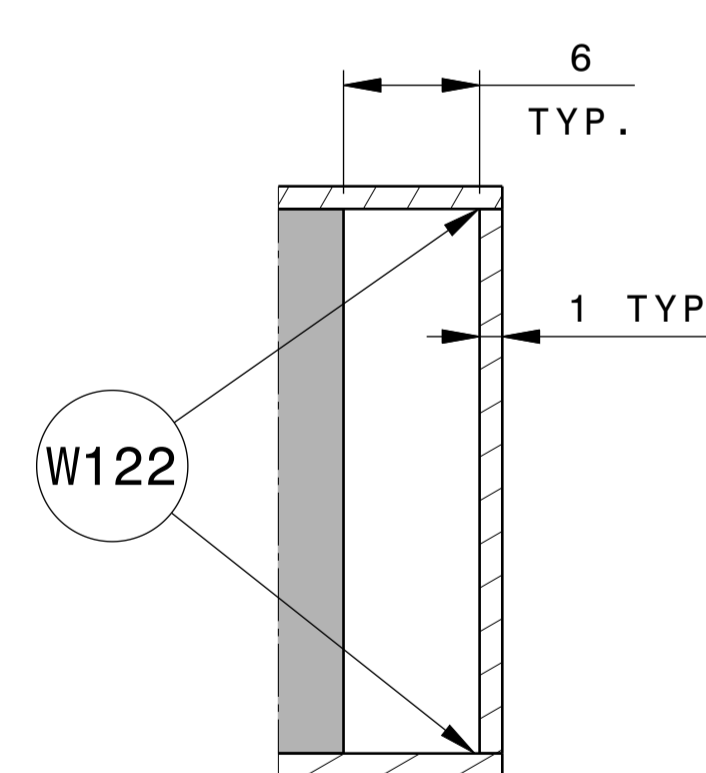

DETAIL F
Scale: 3:1

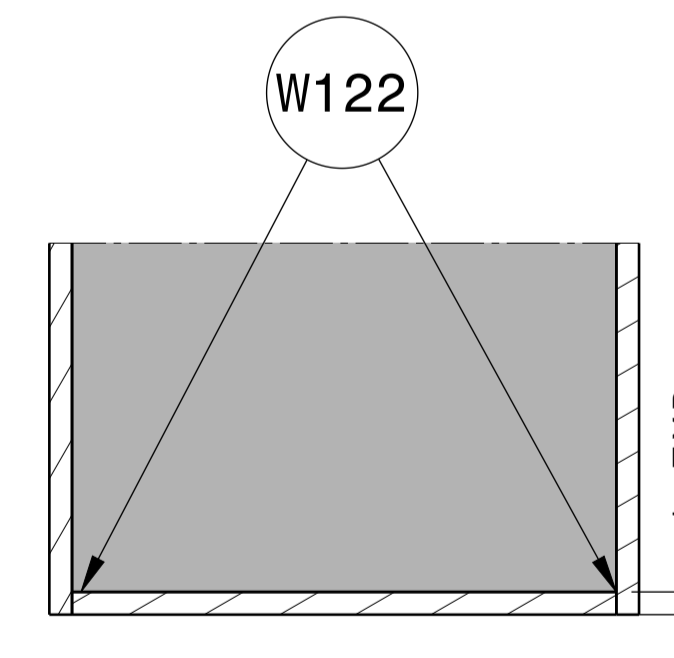

Item No.	Part Number	Revision	Material	Quantity	Weight
1	SIDE_PMS_5L1_CASING#54ZHT6	--A	304L	1	25.562kg
2	SIDE_PMS_5L1_LEAD_PLATE#4LEQ3S	--A	Lead	1	313.738kg

Attribute	Value	Remarks
Material	See BOM	
Mass	See BOM	
General tolerances, unless otherwise stated	ISO 22081:2021 3 A B-B	Tolerancing follow ISO 8015
Specific requirements	Break sharp edges	
Marking		

Note :
 1-Item ② is Cast lead in casing item ①
 2-The welding details are given in the welding table ITER_D_7HMEAR
 3-All dimensions could be controlled under constraints. Tooling could be used to achieve the constraint.

DRW CAD ID	4JYJYS	APPROVED BY	ITER Organization	LEGAL OWNER
LINED REV ID	4U256L	ROTTIC	INTERNAL USE	
LINED 3D ID	4U25WB	TECHNICAL REF	When received pursuant to a contract or agreement, the confidentiality clause entered shall be applicable. When received during tender phase treat as confidential.	
DRS TITLE	Neutral Beam H&OD System HN801 injector Passive magnetic shield	ELOUAZA	iter	
DATE OF ISSUE	16 May 23	NSR	DRAWING TITLE: SIDE_PMS_5L1_CASING_LEAD_PLATE MAIN_VIEWS	
DR STATUS	W	QC-2	DOCUMENT TYPE: Part Drawing	
SCALE	1:15	FORMAT	A1 53 01 PM 06263502 02 --A	